



ENGINEERING-BASED EARTHQUAKE RISK MANAGEMENT

MRP Engineering Newsletter

February 2012

The world recently experienced several major earthquakes, which caused severe local impacts and major worldwide repercussions. Cumulative losses from the 2010 and 2011 earthquakes in Haiti, Chile, New Zealand, and Japan may exceed US\$300 billion. Rebuilding in the affected regions could well span a generation. Structural engineers at MRP Engineering have investigated the impacts and recovery efforts following these events. Based on our observations of damage to structures, equipment systems, and critical lifelines, these events offer many lessons to better manage future seismic risks, as well as teach us how proactive earthquake risk management actions can save lives and protect property. To help organizations better understand potential earthquake impacts to their facilities and make sound proactive risk management decisions (including asset protection, insurance procurement, or refinancing), we propose an engineering-based approach to earthquake risk management. MRP Engineering has applied this approach with success.

LESSONS FROM RECENT EARTHQUAKES

Recent “large-magnitude” earthquakes, such as the M8.8 Maule, Chile, and M9.0 Japan events, highlight the potential long-term economic effects on national economies and regional populations. However, the Haiti and New Zealand earthquakes represent devastating “shallow-depth” events occurring directly under large population centers (long thought to be located in “moderate” seismic hazard zones). Our post-earthquake investigations provide us with first-hand knowledge of the seismic performance of structures, equipment and industrial installations, and regional lifelines. Overall economic losses and long-term implications from these events have been significant. MRP Engineering visited impacted areas to document the earthquake impacts and recovery efforts, as highlighted below. The value of proactive earthquake risk management actions in preventing or minimizing damage and business interruption losses was evident during our investigations.

Event

Major Observations and Lessons



M7.0 January 12, 2010
Haiti

Second-story collapse in a newly constructed hospital in Santo, Haiti

- Strong near-surface earthquake in close proximity to a major population center
- Predominant structures (including schools and hospitals) were comprised of relatively heavy but lightly reinforced concrete frames with unreinforced masonry infill walls
- Local building design and construction standards lack consideration of earthquake forces, resulting in extensive building collapses and considerable loss of life (see adjacent photo)
- Lack of building code enforcement, resulting in poor construction quality
- **Revamped structural engineering and construction practices can result in lower earthquake vulnerability for Haiti.**

Event

Major Observations and Lessons

**M8.8 February 27,
2010, Chile**



Collapsed concrete tilt-up wall panels due to weak wall-to-roof connections

- Subduction-type earthquake resulting in over three minutes of strong ground shaking, which affected modern construction at distant locations
- Coastal communities, infrastructure, and industries affected by tsunami inundation, elevation changes, and soil liquefaction
- Relatively modern seismic design practices on par with 1990s American standards, but some modern structures and contents damaged (including high-rises)
- **Updates to reinforced concrete construction practices are necessary and under consideration.**

**M6.3 February 22, 2011
New Zealand**



Collapsed unreinforced masonry structure in Christchurch

- Shallow-depth earthquake on an unmapped fault in area long considered a “moderate” hazard
- Very high horizontal and vertical accelerations
- Extensive soil liquefaction affecting utilities and building foundations
- Severe damage to some relatively modern multi-story buildings as well as historical masonry structures
- **Major reconstruction planning is underway involving new, existing, and historic buildings.**

**M9.0 March 11, 2011
Japan**



Seismically retrofitted hospital in Minamisanriku survived as a vertical (tsunami) evacuation shelter

- Largest subduction-zone event and tsunami in Japan
- Culture of earthquake preparedness and research with modern seismic design and construction practices
- Tsunami destruction of low-lying coastal communities, lifelines, and industry in the northeast (Tohoku) region, with massive debris and rebuilding required; waterfront facilities in Tokyo (400 km away) impacted
- National power resources (nuclear energy) and international commerce affected
- **Better disaster preparedness and re-evaluation of design and construction standards required.**

EARTHQUAKE RISK

Earthquake risk represents a combination of hazard, vulnerability, and exposure. **Seismic hazard** is the potential for strong ground shaking or other earthquake-related hazards such as settlement, landsliding, ground rupture, or tsunami at a site of interest. **Vulnerability** represents the potential for damage given a facility’s construction, configuration, condition, structural elements, and connections. **Exposure** is a measure of the financial impact should damage occur. Together, vulnerability and exposure describe the consequences of the seismic hazards.



ENGINEERING-BASED APPROACH

Current building codes for new construction focus on the safety of occupants and do not explicitly address damage control or post-earthquake functionality. Since building codes evolve over time as a result of lessons learned from earthquakes and the improved knowledge of potential seismic sources, some existing facilities may not meet the above performance criteria. For others, a greater functionality following a major earthquake may be desired. MRP Engineering's expertise is in developing **engineered solutions** based on your specific risk criteria and a systematic earthquake risk management approach. For existing facilities, this process consists of the following steps:

Approach	Description	Use/Result
Desktop-based	1. Risk screening consists of preliminary identification of facilities located in areas with seismic hazard using generic standardized computer software programs.	<ul style="list-style-type: none"> • Portfolio review and management
Engineering site visit and review	2. Risk assessment for selected facilities provides specific and more detailed potential damage levels and results in quantification of losses, identification of unacceptable exposures, and a prioritized loss-control action plan.	<ul style="list-style-type: none"> • Damage and loss data • Insurance coverage limits • Refinancing info (PML) • Risk-reduction action plan
Structural engineering analysis	3. Risk analysis involves benefit-cost structural analysis of high-risk structures, development of conceptual upgrade solutions to meet performance objectives, and rough-order-of-magnitude upgrade costs.	<ul style="list-style-type: none"> • Facility upgrade planning • Capital budget planning
Design and construction	4. The mitigation phase includes the development of construction documents for structures and equipment, plus implementation of strengthening measures.	<ul style="list-style-type: none"> • Enhanced safety and business protection • Reduced insurance needs

For Step 1, a global seismic hazard (ground shaking only) map that identifies potential high-risk regions may be a convenient first step and preliminary risk screening starting point. Mapped areas in dark red represent the highest potential ground-shaking hazard. Circled areas represent potential zones of M8+ subduction mega-earthquakes that can be accompanied by tsunamis. However, for a specific site of interest, an engineering evaluation (rather than using maps or a desktop assessment) as described in the next section is necessary to better understand impacts from specific ground shaking as well as other seismic hazards such as ground rupture, ground settlement, or soil liquefaction.

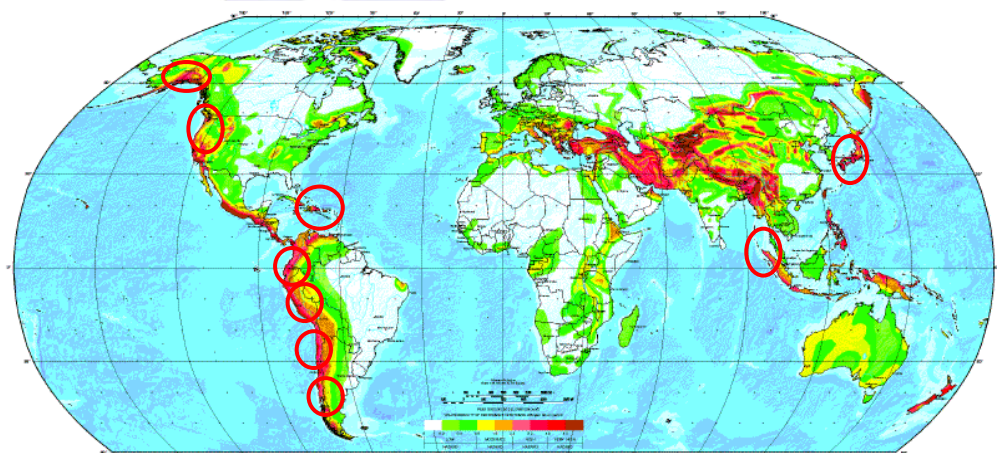

GLOBAL SEISMIC HAZARD MAP

(Source: GSHAP)

ENGINEERING SITE VISIT, REVIEW, AND RISK ASSESSMENT

A facility-specific earthquake risk evaluation (Step 2 in the process) is performed to assess current earthquake vulnerabilities and exposures for the facility, identify potential loss drivers, and develop an action plan with practical strategies that proactively manage unacceptable seismic risks. The risk evaluation involves a site visit, resulting in a report that includes damage scenarios for the structures and equipment, associated probable maximum losses (PMLs), and potential downtimes in the event of a major regional earthquake. The engineering visit focuses on the following:

Site-specific hazards: Soil conditions at a site of interest and type of foundations can have a significant impact on the earthquake response. For example, sites consisting of saturated alluvial (sandy) deposits may experience soil liquefaction, resulting in loss of bearing strength and excessive settlements and leading to significant damage to structures or shallow-bedded utilities (see adjacent photo).

Structures: Some existing structures may not meet the expected seismic performance objectives due to poor structural detailing, weak connections, or irregular geometry. A structural engineering review of design drawings plus a building walk-through can identify potential problems and likely seismic performance.

Equipment and contents: Damage to inadequately restrained equipment and contents can dominate earthquake losses and re-occupancy (see adjacent photos). A walk-through of representative equipment and nonstructural elements, when performed by experienced earthquake engineers, can provide a reasonable assessment of potential equipment risks.

Utilities, lifelines, and business interruption: Understanding of important off-site lifelines, such as electricity, water supply, transportation, and communications is important. An engineering-based risk evaluation includes a review of on-site utilities, off-site lifelines, and backup systems to better understand potential issues that could significantly impact the recovery of operations. Electrical power in particular is key to enable post-event inspections, testing, and eventual start-up or re-occupancy (see adjacent photo). Site access may be impaired due to collapse of key bridges or other infrastructure (see example photo), and this is important to know as part of any post-event recovery plan.

Prioritized loss-control action plan: The risk evaluation report includes a prioritized action plan to address unacceptable earthquake vulnerabilities and exposures. Recommended actions are prioritized based on the following considerations:

- Safety (falling hazards, egress, fire-following-earthquake)
- Prolonged loss of use (structural or equipment damage)
- Excessive property loss (unique or high-value equipment)

Thus, the risk evaluation captures existing risk and loss-control opportunities.

Examples of earthquake impacts:



Soil impacts: repairs of piping damaged by soil liquefaction



Equipment impacts: toppled unrestrained lab workstations



Utility impacts: transformer damage can lead to prolonged downtime



Infrastructure impacts: collapsed bridges may limit site access

DETERMINATION OF PROBABLE MAXIMUM LOSS

The risk evaluation report includes a “loss summary” based on the technical review described above. The risk can be expressed as a probable maximum loss (PML), or cost to restore the structure or facility to pre-earthquake condition, represented in terms of percentage of its replacement value. When coupled with financial values at risk, a loss summary for the existing facility can be used in making property insurance procurement decisions. The table below illustrates potential reduced losses for a “retrofitted” case, assuming that loss-control recommendations are implemented. When reviewing the recommended action plan, this information is very useful in assessing the benefits of seismic risk mitigation, which are described next.

Example Loss Summary

Item	Value	Existing		Retrofitted	
Buildings	\$100 ^M	30%	\$30 ^M	15%	\$15 ^M
Equipment	\$100 ^M	20%	\$20 ^M	10%	\$10 ^M
Time element	\$200 ^M	6 months	\$100 ^M	3 months	\$50 ^M
Total	\$400^M		\$150^M		\$75^M

STRUCTURAL ENGINEERING ANALYSIS, DESIGN, AND CONSTRUCTION (BENEFIT-COST ANALYSIS AND MITIGATION)

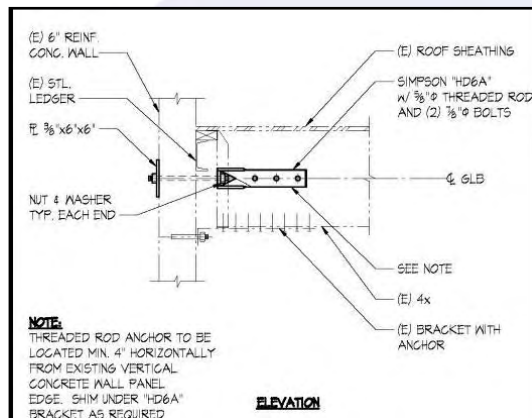

*Example roof-to-wall anchorage retrofit of
tilt-up structure*

As a result of the engineering-based risk evaluation, some structures or equipment may be found to lack key connections and elements to provide adequate performance in a major earthquake. For these assets, a benefit-cost analysis (Step 3) may be conducted to develop concepts of potential upgrade or retrofit measures and provide associated rough-order-of-magnitude costs. As part of this phase, the client should engage a qualified structural engineer to develop upgrade and retrofit alternatives (and costs) for various performance objectives expected of a facility under various earthquake levels. For example, one may consider only a life-safety performance or an operational (minimal facility interruption) performance for a 475-year earthquake event. This process involves site visits to gather additional data and optimize possible engineering solutions. Once an upgrade concept is accepted and a budget approved, final

structural design and development of construction documents is followed by a plan-check submittal with the local jurisdiction (Step 4).

MRP Engineering is ready to assist you with all facets of your earthquake risk-management program, from initial facility risk screening all the way to finalizing design and construction documents for any upgrades, as well as construction support.

MRP ENGINEERING

*MRP Engineering is a structural engineering and risk analysis firm specializing in earthquake engineering. The firm was founded in 2002 and is located in metropolitan Seattle, Washington. Our technical staff actively contributes to the advancement of earthquake engineering standards and routinely investigates performance of structures and systems in actual earthquake events. We assist clients in protecting their business operations from risks to physical assets resulting from extreme events such as earthquakes and hurricanes. Our philosophy is to listen to your needs and then provide you with practical and cost-effective **structural engineering-based risk reduction solutions**. For further information, please contact us at info@mrpengineering.com.*